

Product: KON05 A

Product code: 80529

Contact clamp for lightning conductor

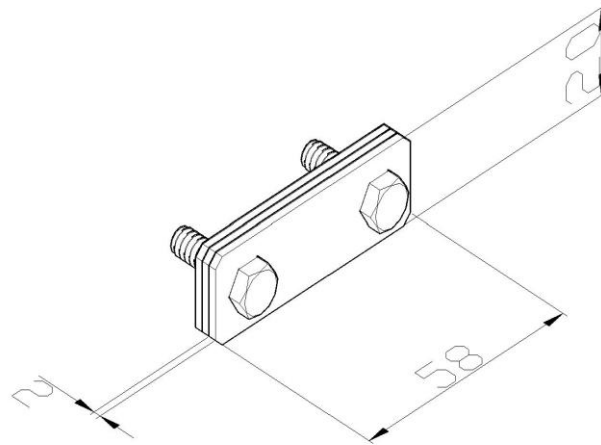

Standard:	EN 62561-1:2017: Lightning Protection System Components (LPSC) - Part 1: Requirements for connection components
Dimensions:	Length: 20 mm
	Width: 58 mm
	Height:
	Weight: 0,04 kg
	Conductor dimensions 1: P up to 30 mm
	Conductor dimensions 2:
Material:	acid-resistant stainless steel
Withstand lightning current class:	