

Product: KON31 M12

Product code: 40641

Clamp intended for potential equalisation

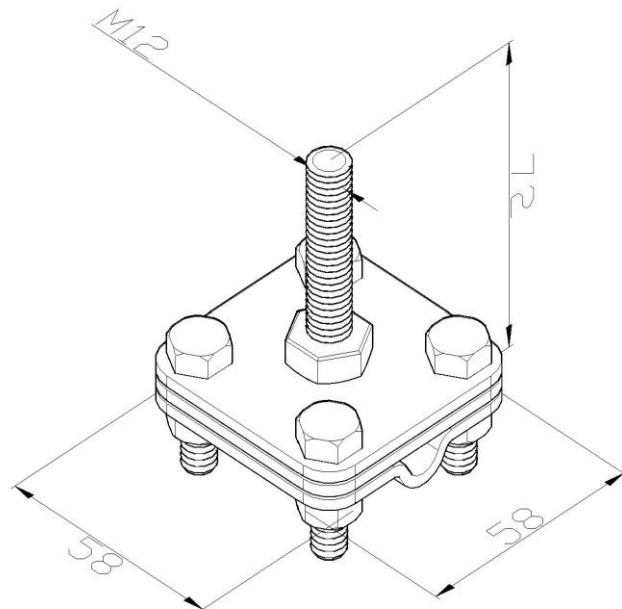

Standard:	EN IEC 62561-2:2018 : Lightning Protection System Components (LPSC) - Part 2: Requirements for conductors and earth electrodes
Dimensions:	Length: 58 mm
	Width: 58 mm
	Height: 72 mm
	Diameter: M12
	Conductor dimensions:
	Weight:
Material:	Acid-resistant stainless steel