

Product: KON03

Product code: 30122

Contact clamp for lightning conductor

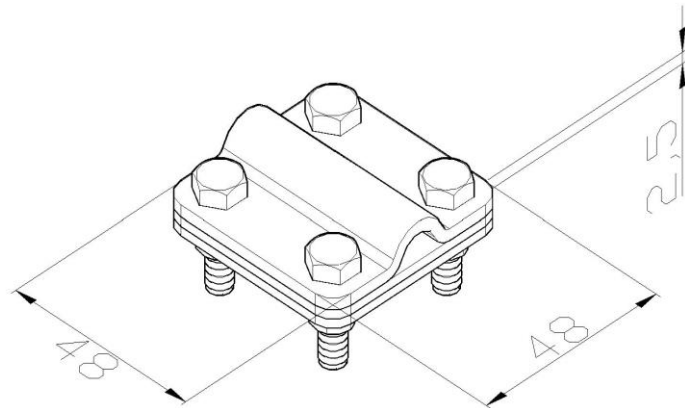

Standard:	EN 62561-1:2017: Lightning Protection System Components (LPSC) - Part 1: Requirements for connection components
Dimensions:	Length: 48 mm
	Width: 48 mm
	Height:
	Weight: 0,14 kg
	Conductor dimensions 1: 16-35 mm ²
	Conductor dimensions 2: P up to 20 mm
Material:	stainless steel
Withstand lightning current class:	H