

Product: LOP2,5 B

Product code: 300584

Lightning rod

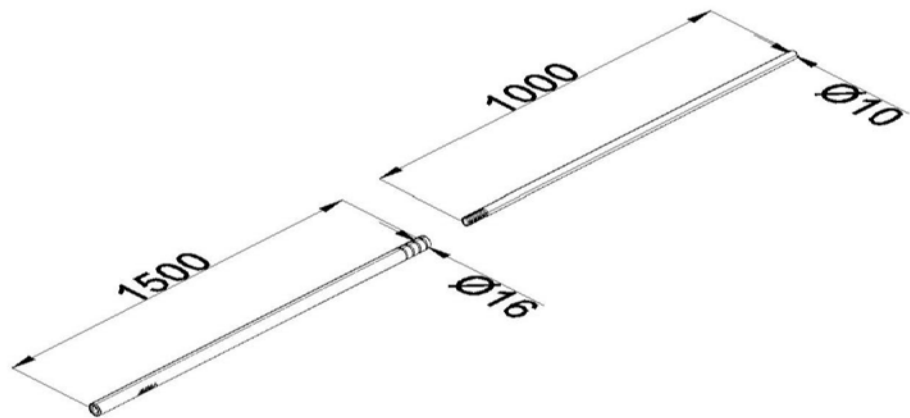

Standard:	EN IEC 62561-2:2018: Lightning Protection System Components (LPSC) - Part 2: Requirements for conductors and earth electrodes
Dimensions:	Length: 2,5 m
	Diameter: ϕ 16/10 mm
	Weight: 0,63 kg
Material:	Aluminium
Maximum wind load:	45 m/s