

Product: LOP2,0 B

Product code: 300583

Lightning rod

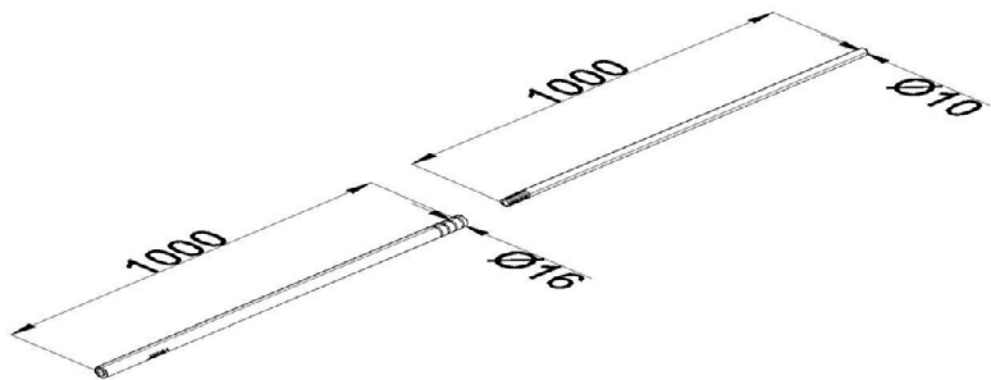

<b>Standard:</b>	EN IEC 62561-2:2018: Lightning Protection System Components (LPSC) - Part 2: Requirements for conductors and earth electrodes
<b>Dimensions:</b>	Length: 2 m
	Diameter: $\phi 16/10$ mm
	Weight: 0,5 kg
<b>Material:</b>	Aluminium
<b>Maximum wind load:</b>	45 m/s