

Product: LOP1,5 B

Product code: 300582

Lightning rod

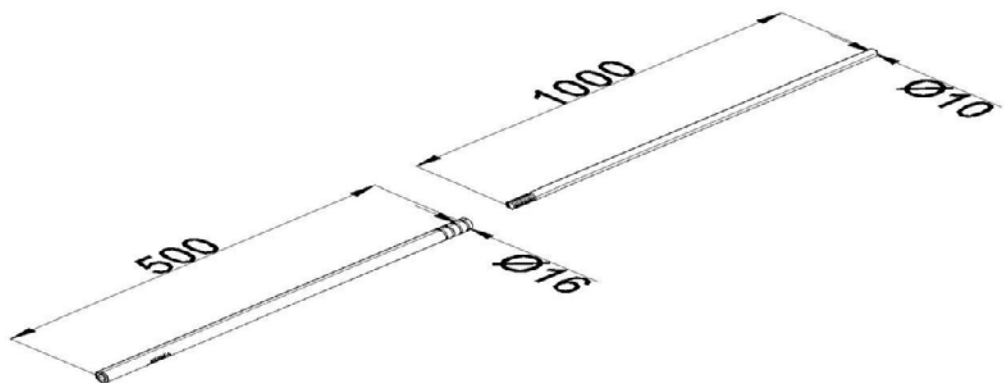

Standard:	EN IEC 62561-2:2018: Lightning Protection System Components (LPSC) - Part 2: Requirements for conductors and earth electrodes
Dimensions:	Length: 1,5 m
	Diameter: $\phi 16/10$ mm
	Weight: 0,37 kg
Material:	Aluminium
Maximum wind load:	45 m/s