

Product: ZON01

Product code: 201250

Wall conductor fastener

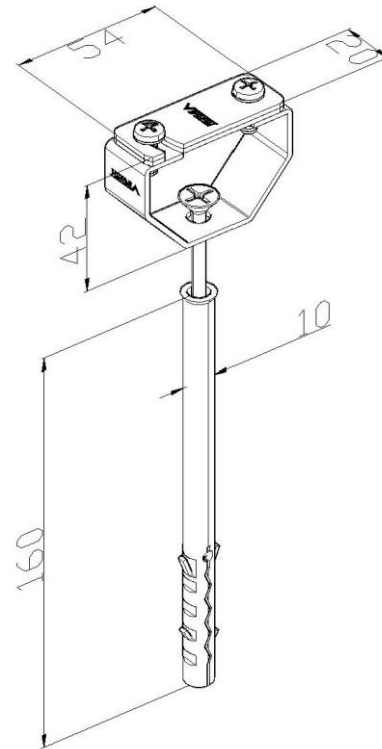

<b>Standard:</b>	EN 62561-4:2017: Lightning protection system components (LPSC) - Part 4: Requirements for conductor fasteners
<b>Dimensions:</b>	Length: 54 mm
	Width: 20 mm
	Height: 42 mm
	Conductor diameter: P up to 30x3,5
	Screw length: 160 mm
	Wall plug diameter: $\phi$ 10 mm
<b>Weight:</b>	0,09 kg
<b>Material:</b>	Stainless steel