

Product: KON27

Product code: 200234

Contact clamp for lightning conductor

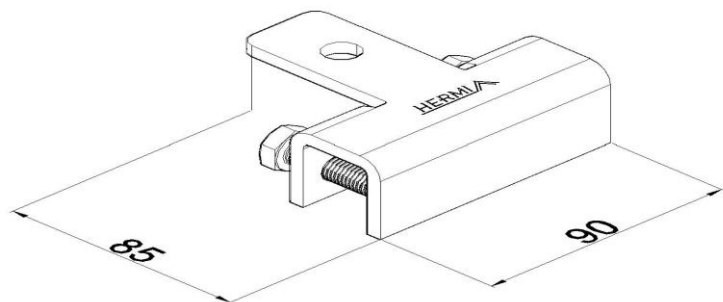

Standard:	EN 62561-1:2017: Lightning Protection System Components (LPSC) - Part 1: Requirements for connection components
Dimensions:	Length: 90 mm
	Width: 85 mm
	Height:
	Weight: 0,32 kg
	Conductor dimensions 1:
Conductor dimensions 2:	
Material:	stainless steel
Withstand lightning current class:	N