

**Product:** SON16 C

**Product code:** 116222

Roof conductor fastener

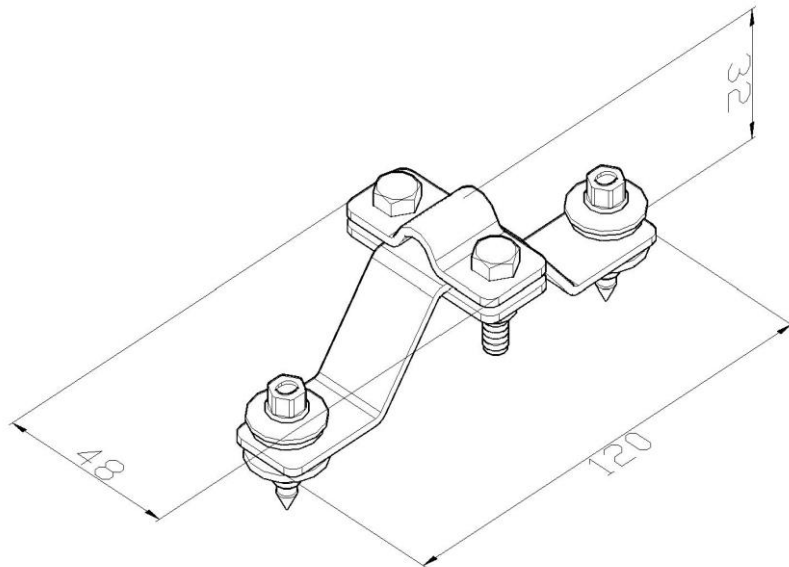

<b>Standard:</b>	EN 62561-4:2017: Lightning protection system components (LPSC) - Part 4: Requirements for conductor fastener
<b>Dimensions:</b>	Length: 120 mm
	Width: 48 mm
	Height: 32 mm
	Conductor diameter: $\phi 8-10$ mm
	Weight: 0,08 kg
<b>Material:</b>	Stainless steel