

Product: PKL-KOB05 52-64

Product code: 88712513

Cable clamp

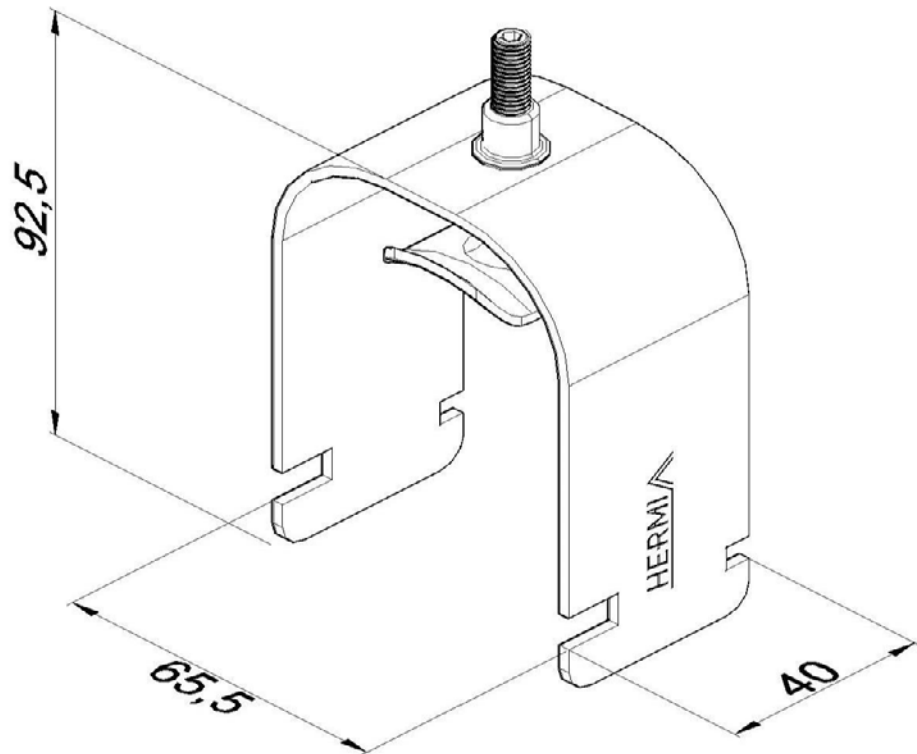

Standard:	EN 61537:2007 Cable management - Cable tray systems and cable ladder systems
Dimensions:	Length: 65,5 mm
	Width: Conductor width 52-64 mm
	Height: 92,5 mm
	Metal thickness: 2 mm
Weight:	0,12 kg
Material:	Stainless steel
Contribution to fire:	Non-flame propagating system
Electrical characteristics:	Electrically conductive system
Electrical continuity:	Yes
Corrosion resistance:	Class 9A
Temperature:	Min: -20°C; Max: +105°C