

Product: NKP-VHP 50-30

Product code: 88707329

Fixing element

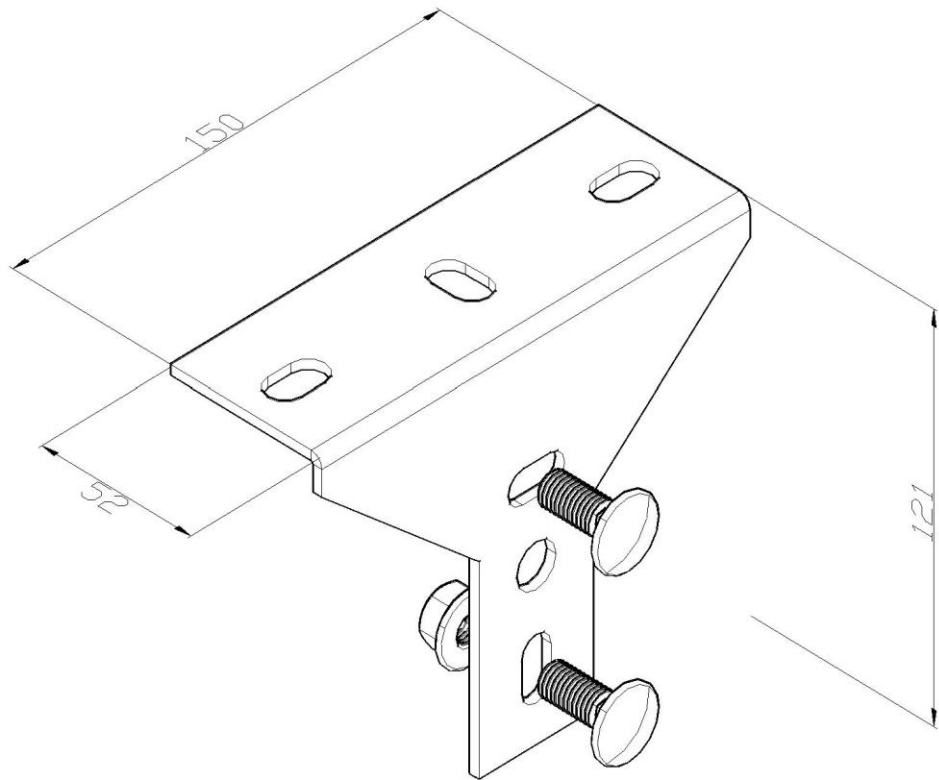

Standard:	EN 61537:2007 Cable management - Cable tray systems and cable ladder systems
Dimensions:	Length: 150 mm
	Width: 52 mm
	Height: 121 mm
	Metal thickness: 3 mm
Maximum load:	
Weight:	0,44 kg
Material:	Galvanised steel
Contribution to fire:	Non-flame propagating system
Electrical characteristics:	Electrically conductive system
Electrical continuity:	Yes
Corrosion resistance:	Class 3
Temperature:	Min: -20°C; Max: +105°C