

Product: NKP-VE 02

Product code: 88702323

Connecting element for mounting SNT to NKP-UL

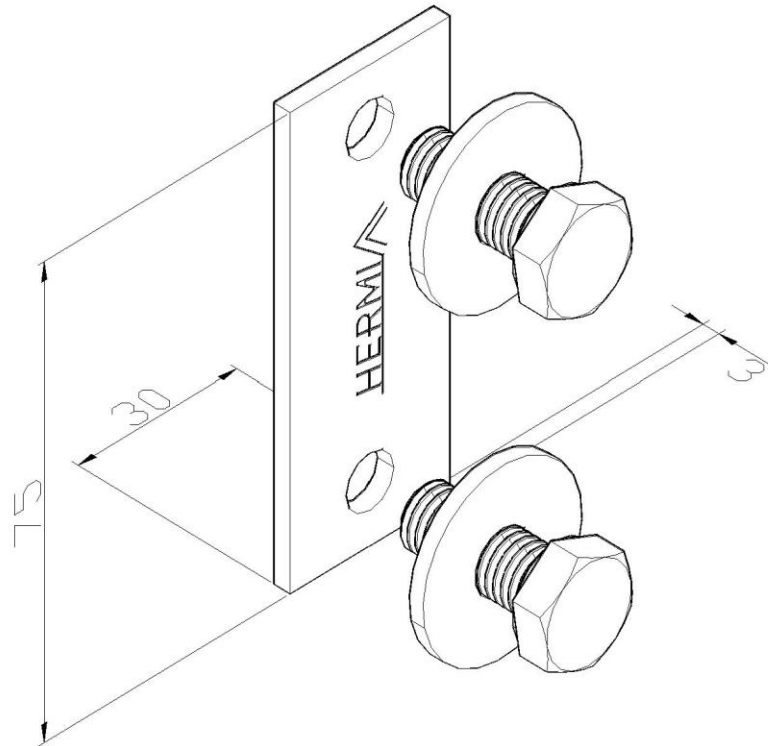

Standard:	EN 61537:2007 Cable management - Cable tray systems and cable ladder systems
Dimensions:	Length: 75 mm
	Width: 30 mm
	Height: 3 mm
	Metal thickness: 3 mm
Maximum load:	
Weight:	0,12 kg
Material:	Stainless steel
Contribution to fire:	Non-flame propagating system
Electrical characteristics:	Electrically conductive system
Electrical continuity:	Yes
Corrosion resistance:	Class 9A
Temperature:	Min: -20°C; Max: +105°C